

Lightning™ 37000D Vector Network Analyzers

40 MHz to 65 GHz

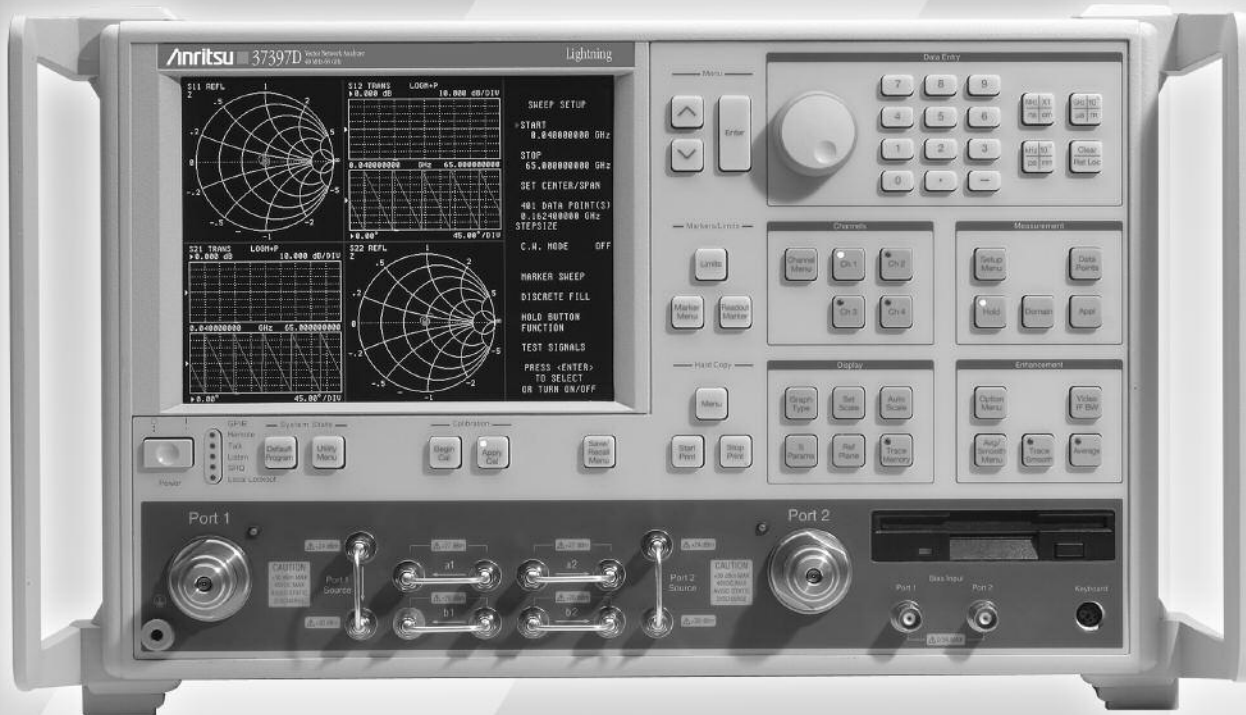

37000D Series

Network Analysis Solutions for Design and Manufacturing

Anritsu

System Description

The Lightning D series microwave and millimeter-wave Vector Network Analyzers encompass a wide range of high performance component and system test tools designed to address the growing needs of defense, satellite, radar, broadband communication, and optoelectronic component markets. The Lightning D series represents the latest improvements to the ever-popular Lightning VNAs to formulate a new range of Network Analyzers with more application features and added options for higher levels of measurement capability. These include Time Domain, Gain Compression, IMD, Frequency Translation, Multiport, Embedding/De-embedding and E/O and O/E measurements, in addition to fast and accurate S-parameter measurements. Complete measurement solutions to 20, 40, 50 and 65 GHz are available in microwave models 37x47D, 37x69D, 37x77D, and 37x97D, respectively.

Standard Features

Measurement Parameters: S11, S21, S22, S12
User-defined combinations of a1, a2, b1, and b2.

Domains: Frequency Domain, CW Draw, and optional High Speed Time (Distance) Domain.

Graph Types: Log Magnitude, Phase, Log Magnitude and Phase, Smith Chart (Impedance), Smith Chart (Admittance), Linear Polar, Log Polar, Group Delay, Linear Magnitude, Linear Magnitude and Phase, Real, Imaginary, Real and Imaginary, SWR and Power Out.

Data Points: 1601 maximum or N discrete data points where $2 \leq N \leq 1601$.

Limits Lines: Either single or segmented limit lines can be displayed. Two limit lines are available for each trace.

Single Limit Readouts: Interpolation algorithm determines the exact intersection frequencies of test data and limit lines.

Segmented Limits: A total of 20 segments (10 upper and 10 lower) can be generated per data trace. Complete segmented traces can be offset in both frequency and amplitude.

Test Limits: Both single and segmented limits can be used for PASS/FAIL testing. The active channel's PASS or FAIL status is indicated on the display after each sweep. In addition, PASS/FAIL status is output through the rear panel I/O connector as selectable TTL levels (PASS = 0V, FAIL = +5V or PASS = +5V, FAIL = 0V).

Tune Mode: Tune Mode optimizes sweep speed in tuning applications by updating forward S-parameters more frequently than reverse ones. This mode allows the user to select the ratio of forward sweeps to reverse sweeps after a full 12-term calibration. The ratio of forward sweeps to reverse sweeps can be set anywhere between 1:1 and 10,000:1.

Data Averaging: Point-by-point (default) {up to 4096}
Sweep-by-Sweep

IF Bandwidth: 10 kHz – 10 Hz

Reference Plane: Can be entered in time or in distance (when the dielectric constant is entered). Automatic reference plane feature adds the correct electrical length (delay) compensation. Software compensation for the electrical length difference between reference and test is always accurate and stable since measurement frequencies are always synthesized. In addition, the system compensates reference phase delay for dispersive transmission media, such as waveguide and microstrip.

Measurement Frequency Range: Frequency range of the measurement can be narrowed within the calibration range without recalibration. CW mode permits single frequency measurements, also without recalibration.

Group Delay Aperture: Defined as the frequency span over which the phase change is computed at a given frequency point. The aperture can be changed without recalibration. The minimum aperture is the frequency range divided by the number of points in calibration and can be increased to 20% of the frequency range without recalibration.

Measurement Channels: Four independent channels are available to display any S-parameter or user defined parameter, in any format, with up to two traces per channel for a maximum of eight traces simultaneously. A single channel, two channels (1 and 3, or 2 and 4), or all four channels can be displayed simultaneously. Channels 1 and 3, or channels 2 and 4 can be overlaid.

Display: Color LCD, 8.5" diagonal.

Display Colors: The color of data traces, memory, text, markers and limit lines are all user definable.

Trace Overlay: Displays two data traces on the active channel's graticule simultaneously.

Trace Memory: A separate memory for each channel can be used to store measurement data for later display or subtraction, addition, multiplication or division with current measurement data.

Group Delay Range: The maximum delay range is limited to measuring no more than +180° of phase change within the aperture set by the number of frequency points.

Scale Resolution (minimum per division):

Log Magnitude	0.001 dB
Linear Magnitude	1 pU
Phase	0.01°
Group Delay	0.001 ps
Time	0.001 ms
Distance	0.1 μm
SWR	1 pU
Power	0.01 dB

Markers: Six independent markers can be used to read out measurement data.

Delta Marker: One marker can be selected as the reference for the other five.

Enhanced Markers: Marker search feature can be used for finding a level or bandwidth on the active channel.

Marker Sweep: Sweeps upward in frequency between any two markers. Recalibration is not required during the marker sweep.

Blank Frequency Information: Blanking function removes all references to frequencies on the display. Frequency references can only be restored through a system reset or GPIB command.

Vector Error Correction:

There are six built-in methods of calibration:

Short-Open-Load-Thru (SOLT): This calibration method uses short circuits, open circuits, and terminations (fixed or sliding).

Offset-Short (waveguide): This calibration method uses short circuits and terminations.

LRL/LRM: The Line-Reflect-Line (LRL) or Line-Reflect-Match (LRM) calibration uses transmission lines and a reflective device or termination (LRM).

TRM: The Thru-Reflect-Match calibration uses short circuits and fixed termination.

Three Offset-Short (SSST): This calibration method uses three short circuits with different offset lengths to calculate all the calibration terms.

Autocal: This calibration method uses an automatic calibrator module.

There are four vector error correction models available for calibration:

- 1) Full 12-Term
- 2) One Path/Two Port
- 3) Frequency Response
- 4) Reflection Only

Merged Calibrations: In addition, the Lightning D series VNAs have a Merged Calibration feature that allows the user to merge calibrations performed under different conditions (such as a low frequency SOLT with a band-limited LRL) to cover different frequency bands, provided the total number of points does not exceed 1601.

AutoCal®: The VNA can internally control an external AutoCal module to perform a 2-port OSLT calibration. AutoCal is a single two port calibration module with built-in, switched, and characterized OSLT standards. AutoCal provides quick, reliable, and accurate calibrations that exceed the performance of a standard broadband load OSLT calibration.

Calibration Standards: For coaxial calibrations the user can select between SMA, 3.5 mm, GPC-7, Type N, 2.4 mm, TNC, K, V, W1 connector or special type from the calibration menu. Use of fixed or sliding loads can be selected for each connector type. User defined calibration standards allow for entry of open capacitance, load and short inductances, load impedance, and reflection standard offset lengths.

Reference Impedance: It is possible to modify the reference impedance of the measurement to other than 50Ω (but not 0).

Adapter Removal Calibration: Built-in Adapter Removal application software accurately characterizes and "removes" any adapter used during calibration that will not be used for subsequent device measurements. This technique allows for accurate measurement of non-insertable devices.

Dispersion Compensation: Selectable as Coaxial (nondispersive), Waveguide, or Microstrip (dispersive).

Power Meter Correction: Power meter correction is available at a user-selectable power level, if it is within the power adjustment range of the internal source. This is performed using an external power meter over the Dedicated GPIB port

Multiple Source Control Capability: Multiple Source Control capability allows a user to independently control the frequencies of two sources and the receiver without the need for an external controller PC. The frequency sweep may be comprised of up to five separate bands, each with independent source and receiver settings, for convenient testing of mixers, multipliers and other frequency translated devices.

Set-On Receiver Mode: For applications that require Harmonics or Intermodulation measurement, the 37000D can be configured to measure the relative harmonic level of test devices with Set-On Receiver Mode capability. The 37000D's unique phase locking scheme allows it to operate as a tuned receiver by locking all of its local oscillators to its internal crystal reference oscillator.

Embedding/De-embedding: All 37000D are equipped with an Embedding/De-embedding feature. De-embedding is generally used for removal of test fixture contributions and other S2P networks from measurements. The de-embedding can be applied to a calibration and then stored for future measurements. Similarly, the Embedding function can be used to simulate matching circuits for optimizing amplifier designs or simply adding effects of a known structure to a measurement.

Electro-Optical Measurements

The 37000D series incorporated a de-embedding function that simplifies VNA calibration when measuring E/O and O/E devices. Characterize the transfer function, group delay, and return loss of optical modulators (E/O) and photoreceivers (O/E) using the built-in application.

E/O Measurements: The application menu guide the user through the entire calibration and setup. A characterized photodiode (O/E) reference and a laser source are required to complete the test setup. The internal VNA application de-embeds the response of the photodiode reference to allow direct measurement of the bandwidth and return loss of the modulator.

O/E Measurements: Photoreceiver measurements can be made by characterizing a modulator first and then using it as a transfer standard for the O/E measurement. The internal application de-embeds the response of the modulator to allow characterization of the photoreceiver.

Gain Compression Measurements (37300D models only)

The 37300D series provide a user-intuitive Gain Compression and AM/PM measurement application. The following two methods are available for making gain compression measurements.

Swept Power Gain Compression: The VNA displays traditional Power out vs. Power in or Phase vs. Power in, at one of up to 10 selectable CW frequencies. A separate screen will easily show Power out and Power in at 1 dB or selected Gain compression for all entered frequencies.

Swept Frequency Gain Compression: Once Gain is measured at the starting power, the user increments Power in, observing Normalized Gain vs. Frequency. This aids in analyzing the most critical compression frequencies of a broadband amplifier.

Connectivity

GPIB: 2 Ports, system GPIB and dedicated GPIB

System GPIB (IEEE-488.2): Connects to an external controller for use in remote programming of the network analyzer. Address can be set from the front panel and can range from 1 to 30.

Dedicated GPIB: Connects to external peripherals for network analyzer controlled operations (e.g., GPIB plotters, frequency counters, frequency synthesizers and power meters).

GPIB Data Transfer Formats: ASCII, 32-bit floating point, or 64-bit floating point. 32-bit and 64-bit floating point data can be transferred with LSB or MSB first.

Measurement Throughput: Measurement times are based on a single 40 MHz to 20 GHz sweep with 10 kHz IF bandwidth (no averages) after a full 12-term calibration. Sweep times include retrace and band switch times.

Measurement Time (ms) vs. 101 Data Points (typical)

Calibration Type	Data Points				
	3	51	101	401	1601
1 Port (3 Term)	75	270	350	920	3000
2 Port (12 Term)	60	250	340	920	3000

Measurement Time vs. Sweep Mode for 101 Data Points (typical)

Sweep Mode	Time (ms)
Linear	350
List	350
CW	190

Measurement Time vs. IF BW for 101 Data Points (typical)

IF Bandwidth	Time (ms)
10 kHz	180
1 kHz	270
100 Hz	1100
10 Hz	7300

Measurement Time vs. Span for 101 Data Points (typical)

Frequency Span	Time (ms)
40 MHz to 65 GHz	900
40 MHz to 40 GHz	450
20 GHz to 40 GHz	340
10 GHz to 11 GHz	220

GPIB Data Transfer Speed (with or without cal): 240 kB/sec

GPIB Data Throughput Time: Throughput measurements for both tables were made as follows: start the timer, trigger a sweep, wait for a full sweep, transfer data across the GPIB and stop the timer. Data throughput times are shown separately for measurements made without calibration and with full two-port, 12-Term calibration. Measurement conditions: 40 MHz to 20 GHz sweep, single channel, log magnitude display, 10 kHz IF bandwidth, and output final data.

Throughput Times (ms) without Correction (typical)

Data Format	3 Points ¹	101 Points	401 Points	1601 Points
32 Bit	40	400	1000	3000
64 Bit	40	400	1000	3000
ASCII	40	450	1200	3600

¹: 3 data point sweeps taken at 2, 4, and 6 GHz.

Throughput Times (ms) with 12-Term Correction (typical)

Data Format	3 Points ¹	101 Points	401 Points	1601 Points
32 Bit	80	800	1900	5800
64 Bit	80	800	1900	5800
ASCII	80	850	2100	6300

¹: 3 data point sweeps taken at 2, 4, and 6 GHz.

Fast CW Operation: Fast CW is an ideal mode of operation for rapid data taking over GPIB. To achieve a fast measurement rate the display is not updated and only the raw S-parameter or user-defined parameter of the active channel is measured.

Fast CW Typical Performance

Trigger Mode	Measurement Speed (ms/point)
GPIB	1.5
External TTL	1.2
Internal	0.8

Internal Buffer Data Collection: Internal Buffer Data Collection is provided to allow saving active channel measurement data from multiple sweeps without having to synchronize and collect data at the end of each sweep. The 37000D can store up to 50,000 data point measurements, each consisting of two (real and imaginary) IEEE 754 4-byte floating point numbers. GPIB transfer speed for the 50,000 data points is typically 2.2 seconds.

Ethernet Port: 10/100 Base T

Ethernet Data transfer speed (with or without cal): 850 kB/s (typical)

Printer Port: Parallel port, 25 pin

Serial Port: Control Signals +5V TTL, also used for AutoCal[®] control

External I/O: Connects to external test sets, 25 pin DSUB connector

Storage

Internal Hard Disk Drive: 0.5 GB, used to store and recall measurement and calibration data and front-panel setups. File names can be 1 to 8 characters long, and must begin with a character, not a number. Extensions are automatically assigned.

Internal Memory: Ten front panel states (no calibration) can be stored and recalled from non-volatile memory locations. The current front panel setup is automatically stored in non-volatile memory at instrument power-down. When power is applied, the instrument returns to its last front panel setup.

External SCSI Interface: Option 4 deletes the internal hard disk drive, and adds a SCSI Interface connector to the rear panel for connecting a SCSI-2 formatted storage drive (available as an accessory).

Internal Floppy Disk Drive: A 3.5-inch diskette drive with 1.44 Mbytes formatted capacity is used to load measurement programs and to store and recall measurement and calibration data and front-panel setups. Measurement data can be stored in text, S2P or bitmap format. File names can be 1 to 8 characters long and must begin with a character, not a number. Extensions are automatically assigned.

Measurement Data: 102.8 kB per 1601 point S-parameter data file.

Calibration Data: 187.3 kB per 1601 point S-parameter data file (12-Term cal plus setup).

Trace Memory File: 12.8 kB per 1601 point channel.

Interfaces

Front Panel Connectors and Controls:

Keyboard Input: Any PS-2 keyboard can be connected to the front panel for navigating through front panel menus, annotation of data files and display labels, printing displays and pausing instrument sweeps.

Test Ports: Universal K male test ports are standard on the 37X47D and 37X69D models, and the Universal V male test ports are standard on the 37X77D and 37X97D models. For additional configurations check Test Port Converters (Option 7).

Bias Inputs, Port 1 and 2 (37300D): 0.5 amps maximum through BNC connectors.

Option 15 ports: K-female provided on the 37X47D and 37X69D models, and V-female ports provided on the 37X77D and 37X97D models. Please refer to Flexible test set option section for power ratings of ports.

Rear Panel Connectors and Controls:

VGA Out: Provides VGA output of 37000D video display.

Serial: 9-Pin male D-SUB connector. Provides RS-232 serial port control for an AutoCal® module (3658 series).

10 MHz REF In: Connects to external reference frequency standard, 10 MHz, +5 to -5 dBm, 50Ω, BNC female.

10 MHz REF Out: Connects to internal reference frequency standard, 10 MHz, 0 dBm, 50Ω, BNC female.

Ext Analog Out: -10V to +10V with 5 mV resolution, varying in proportion to user-selected data (e.g., frequency, amplitude). BNC female.

Ext Analog In: ±50 volt input for displaying external signals on the LCD. BNC female.

Line Selection: Power supply automatically senses 100V, 120V, 220V or 240V lines.

External Trigger: External TTL triggering for 37000D measurement. 10 kΩ input impedance, BNC female.

Printer Port: A standard parallel port interfaces to most printers for printing full screen graphical and tabular data.

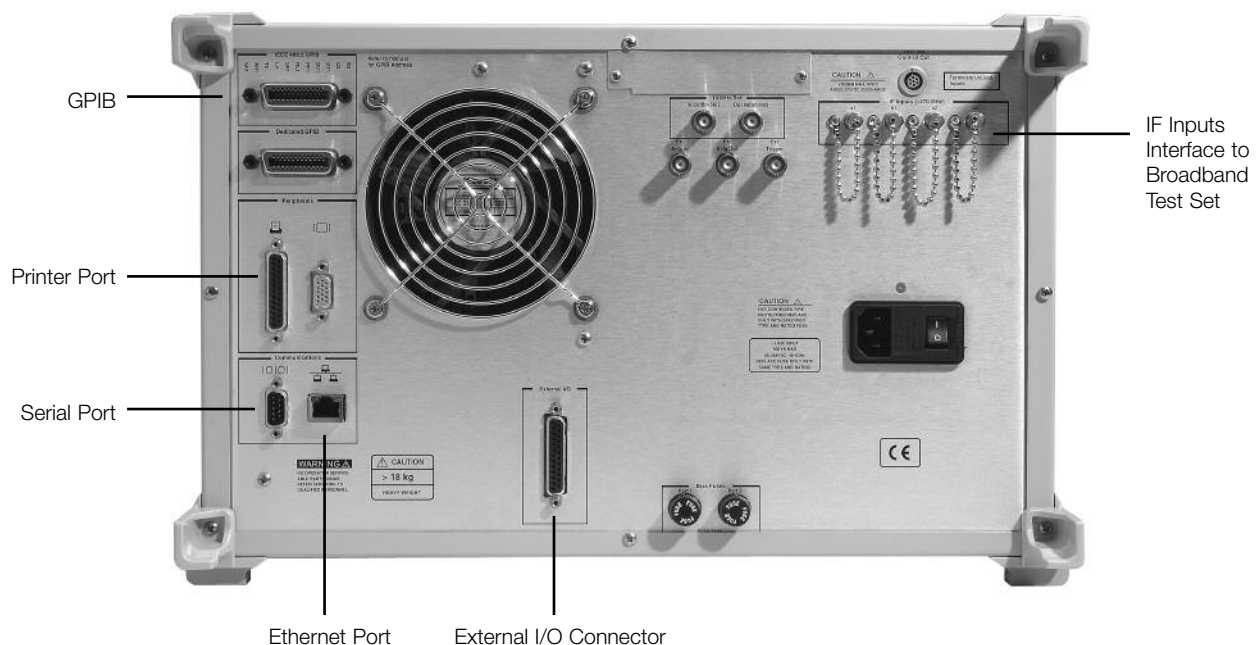

Options

Time (Distance) Domain Measurement Capability (Option 2A)

High Speed Time (Distance) Domain option allows the conversion of reflection or transmission measurements from the frequency domain to the time domain. Measured S-parameter data is converted to the time domain by application of a Fast Fourier Transform (FFT) using the Chirp Z-Transform technique. Prior to conversion, any one of several selectable windowing functions may be applied. Once the data is converted to the time domain, a gating function may be applied to select the data of interest. The processed data may then be displayed in the time domain with display start and stop times selected by the user or in the distance domain with display start and stop distance selected by the user. The data may also be converted back to the frequency domain with a time gate to view the frequency response of the gated data.

The following modes are available within the Time Domain option:

Lowpass Mode: This mode displays a response equivalent to the classic "TDR" (Time Domain Reflectometer) response of the device under test and provides the best resolution. Lowpass response may be displayed in either the Impulse or Step mode. This type of processing requires a sweep over a harmonic series of frequencies and an extrapolated or user-entered DC value.

Bandpass Mode: This mode displays a response equivalent to the time response of the device under test to a band limited impulse. This type of processing may be used with any arbitrary frequency sweep range, limited only by the test set range or device under test response.

Phasor Impulse Mode: This mode displays a response similar to the Lowpass impulse response, using data taken over an arbitrary (band limited) sweep range. Detailed information, similar to that contained in the lowpass impulse response may be used to identify the nature of impedance discontinuities in the device under test. Now, with Phasor Impulse, it is possible to characterize complex impedances on band-limited devices.

The following windows may be applied to the frequency data in the time domain mode.

Windowing: Any one of four window functions may be applied to the initial frequency data, to counteract the effects of processing data with a finite bandwidth. These windows provide a range of trade offs of main lobe width versus side lobe level (ringing). The general type of function used is the Blackman-Harris window with the number of terms being varied from one to four. Typical performance follows:

Type of Window (Number of Terms)	First Side Lobe Relative to Peak	Impulse Width ¹
Rectangle (1)	-13 dB	1.2W
Nominal-Hamming (2)	-43 dB	1.8W
Low Side Lobe, Blackman-Harris (3)	-67 dB	2.1W
Minimum Side Lobe, Blackman-Harris (4)	-92 dB	2.7W

1: W (Bin Width) = 1/2Δf sweep width.

Gating: A selective gating function may be applied to the time domain data to remove unwanted responses, either in a pass-band or reject-band (mask). This gating function may be chosen as the convolution of any of the above window types with a rectangular gate of user defined position and width. The gate may be specified by entering start and stop times or center and span. The gated data may be displayed in the time domain, or converted back to the frequency domain.

Range:

The unaliased (non-repeating) time range is given by the formula:

$$\text{Unaliased Range (ns)} = \frac{\text{Number of Frequency Data Points}}{\text{Frequency Sweep Range (GHz)}}$$

The resolution is given by the formula:

$$\text{Main Lobe Width (null-null) in ns} = \frac{kW}{\text{Frequency Sweep Range (GHz)}}$$

where kW is two times the number of window terms (for example, four for a two-term window)

Frequency with Time Gate: Data that has been converted to time domain and selected by the application of gating function may be converted back to the frequency domain. This allows the display of the frequency response of a single element contained in the device under test. Frequency response accuracy is a function of window and gate type, and gate width. For a full reflection, minimum gate and window accuracy is within 0.2 dB of the un-gated response over a 40 GHz range.

Flexible Test Set (Option 15)

This option provides direct access to all the non-ratioed channels, namely a1 (Ref. A), a2 (Ref. B), b1 (Test A), and b2 (Test B), from the front panel. This is useful for antenna measurements, frequency translated device measurements (mixers, multipliers) and external test set additions (such as for multipoint applications).

This option also adds an auxiliary source loop on each port to allow the addition of external devices. Thus, an amplifier or attenuator can be added to either boost the available power from each port or to further extend the ALC range of the instrument.

Port	Max. Signal Into Port (dBm)
a1	27
a2	27
b1	20
b2	20
Src. 1	30
Src. 2	30

(see pages 11–12 for block diagrams)

Corrected Specifications

37X47D (40 MHz – 20 GHz)

System Dynamic Range is defined as the difference between the available power from Port 1 incident on Port 2 in a through line connection and the noise floor.

VNA settings: 10 Hz I.F. Bandwidth, 101 pts, 12-term SOLT calibration, 512 averages

Model	Frequency ¹ (GHz)	Port 1 Power, Typical (dBm)		Noise Floor at Port 2 (dBm) ²		System Dynamic Range (dB)	
			With Option 15		With Option 15		With Option 15
37347D	0.04	10	10	-82	-82	92	92
	2	11	11	-104	-104	115	115
	20	8	7	-100	-99	108	106
37247D	0.04	10	10	-82	-82	92	92
	2	11	11	-104	-104	115	115
	20	7	6	-101	-100	108	106

Test Port Characteristics³

Connector	Frequency ¹ (GHz)	Directivity (dB)	Source Match (dB)	Load Match (dB)	Reflection Tracking (dB)	Transmission Tracking (dB)	Isolation (dB)
K (2.92 mm)	0.04	>42	>40	>42	±0.005	±0.030	>105
	2	>42	>40	>42	±0.005	±0.030	>105
	20	>42	>38	>42	±0.006	±0.070	>110

NOTES: 1. Specifications between the stated frequencies are to be linearly interpolated as typical values.

2. RMS values – compensated for loss in available source power from test port cable connected between Port 1 and Port 2.

3. The specifications for Test Port Characteristics apply when the VNA Universal Test Port Adapters are connected, with or without phase equal insertables, to the test set ports and calibrated with the appropriate calibration kit at 23°C ±3°C using the SOLT calibration method with a sliding load to achieve 12-term error correction. (90 min. warm-up time is recommended.)

Measurement Uncertainty

The graphs give measurement uncertainty after 12-Term vector error correction. The errors are worst case contributions of residual directivity, load and source match, frequency response, isolation, network analyzer dynamic accuracy, and connector repeatability.

Reflection Measurements

Reflection Magnitude Uncertainty
37x47D/3652/Reflection Only

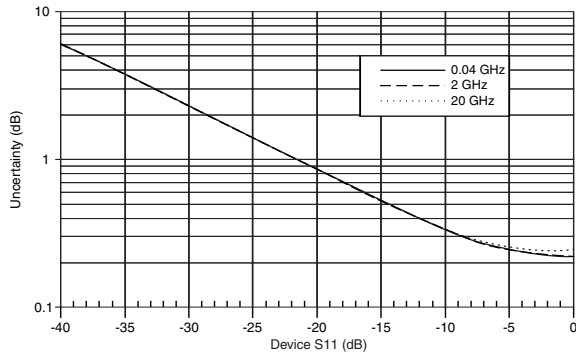

Reflection Phase Uncertainty
37x47D/3652/Reflection Only

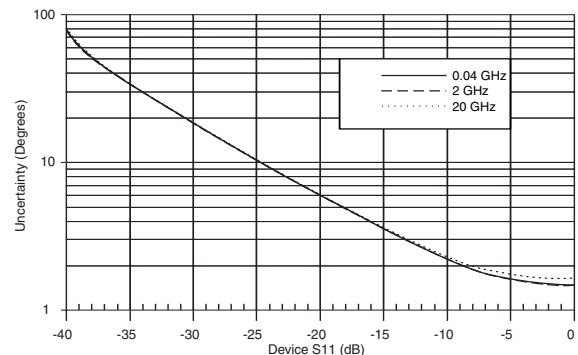

Transmission Measurements

Transmission Magnitude Uncertainty
37x47D/3652/Transmission Only

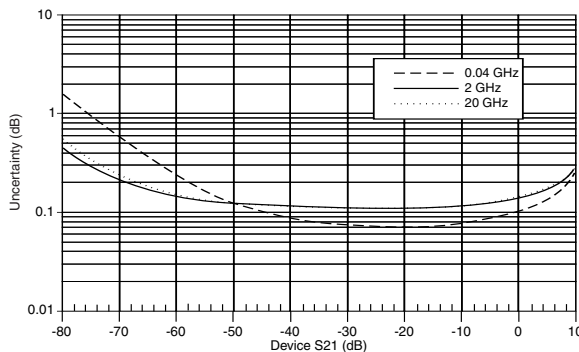

Transmission Phase Uncertainty
37x47D/3652/Transmission Only

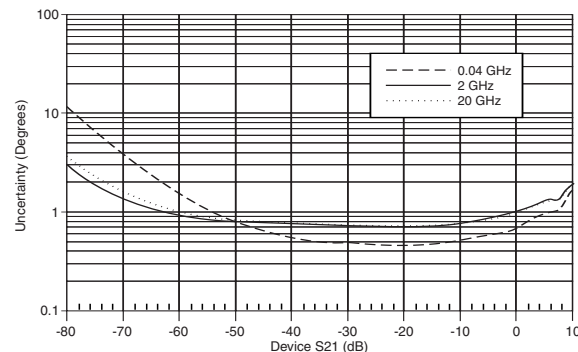

37X69D (40 MHz – 40 GHz)

Model	Frequency ¹ (GHz)	Port 1 Power, Typical (dBm)		Noise Floor at Port 2 (dBm) ²		System Dynamic Range (dB)	
			With Option 15		With Option 15		With Option 15
37369D	0.04	10	10	-85	-85	95	95
	2	8	8	-107	-107	115	115
	20	3	2	-103	-102	106	104
	40	2	1	-95	-94	97	95
37269D	0.04	10	10	-85	-85	95	95
	2	8	8	-107	-107	115	115
	20	2	1	-104	-103	106	104
	40	2	1	-97	-96	99	97

Test Port Characteristics³

Connector	Frequency ¹ (GHz)	Directivity (dB)	Source Match (dB)	Load Match (dB)	Reflection Tracking (dB)	Transmission Tracking (dB)	Isolation (dB)
K (2.92 mm)	0.04	>42	>40	>42	±0.005	±0.030	>105
	2	>42	>40	>42	±0.005	±0.030	>105
	20	>42	>38	>42	±0.006	±0.070	>110
	40	>38	>34	>38	±0.006	±0.080	>100

NOTES: 1. Specifications between the stated frequencies are to be linearly interpolated as typical values.

2. RMS values – compensated for loss in available source power from test port cable connected between Port 1 and Port 2.

3. The specifications for Test Port Characteristics apply when the VNA Universal Test Port Adapters are connected, with or without phase equal insertables, to the test set ports and calibrated with the appropriate calibration kit at 23°C ±3°C using the SOLT calibration method with a sliding load to achieve 12-term error correction. (90 min. warm-up time is recommended.)

Measurement Uncertainty

The graphs give measurement uncertainty after 12-Term vector error correction. The errors are worst case contributions of residual directivity, load and source match, frequency response, isolation, network analyzer dynamic accuracy, and connector repeatability.

Reflection Measurements

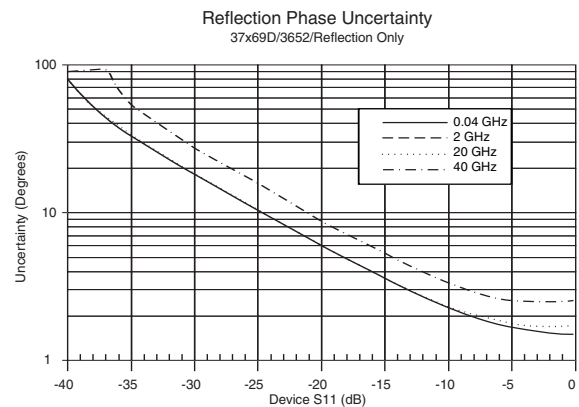
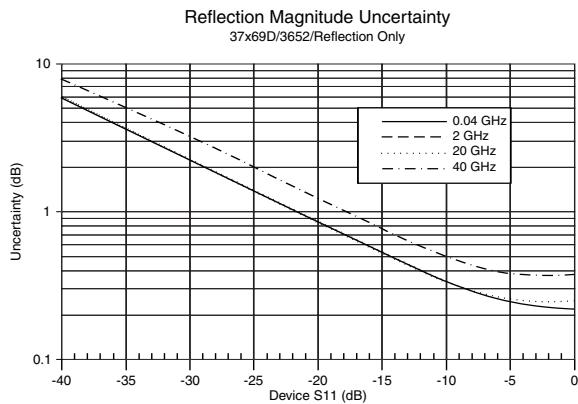

Transmission Measurements

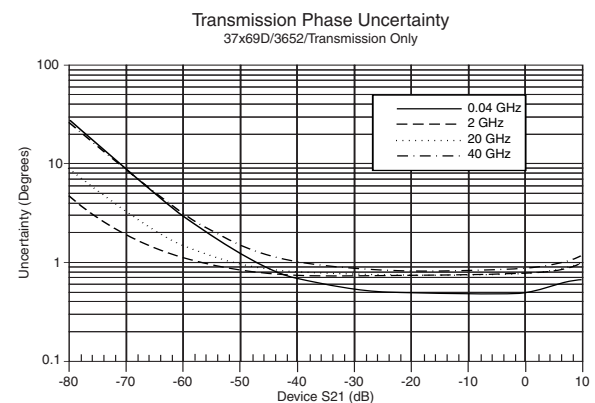
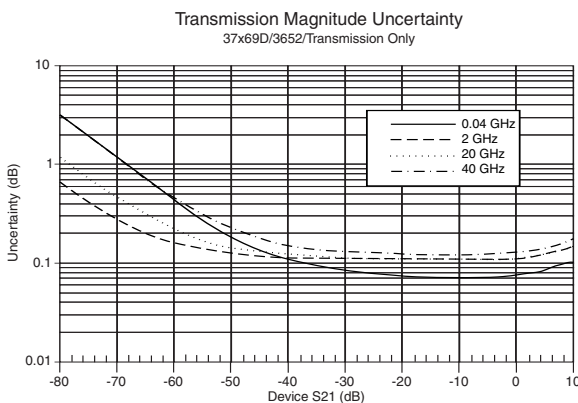

37X77D (40 MHz – 50 GHz)

Model	Frequency ¹ (GHz)	Port 1 Power, Typical (dBm)		Noise Floor at Port 2 (dBm) ²		System Dynamic Range (dB)	
			With Option 15		With Option 15		With Option 15
37377D	0.04	10	10	-88	-88	98	98
	2	5	5	-110	-110	115	115
	20	2	1	-106	-105	108	106
	40	1	0	-98	-97	99	97
	50	-1	-3	-94	-93	93	90
37277D	0.04	10	10	-88	-88	98	98
	2	5	5	-110	-110	115	115
	20	1	0	-107	-106	108	106
	40	1	0	-100	-99	101	99
	50	-1	-3	-96	-95	95	92

Test Port Characteristics³

Connector	Frequency ¹ (GHz)	Directivity (dB)	Source Match (dB)	Load Match (dB)	Reflection Tracking (dB)	Transmission Tracking (dB)	Isolation (dB)
V (1.85 mm)	0.04	>40	>36	>40	±0.050	±0.050	>115
	2	>40	>36	>40	±0.050	±0.050	>115
	20	>40	>36	>40	±0.060	±0.070	>110
	40	>36	>32	>36	±0.060	±0.080	>100
	50	>34	>30	>34	±0.080	±0.100	>90

- NOTES: 1. Specifications between the stated frequencies are to be linearly interpolated as typical values.
 2. RMS values – compensated for loss in available source power from test port cable connected between Port 1 and Port 2.
 3. The specifications for Test Port Characteristics apply when the VNA Universal Test Port Adapters are connected, with or without phase equal insertables, to the test set ports and calibrated with the appropriate calibration kit at 23°C ±3°C using the SOLT calibration method with a sliding load to achieve 12-term error correction. (90 min. warm-up time is recommended.)

Measurement Uncertainty

The graphs give measurement uncertainty after 12-Term vector error correction. The errors are worst case contributions of residual directivity, load and source match, frequency response, isolation, network analyzer dynamic accuracy, and connector repeatability.

Reflection Measurements

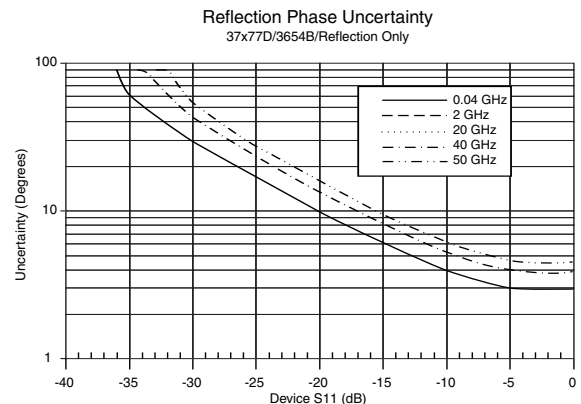
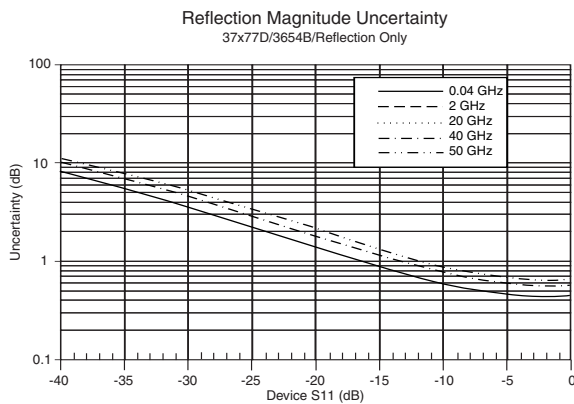

Transmission Measurements

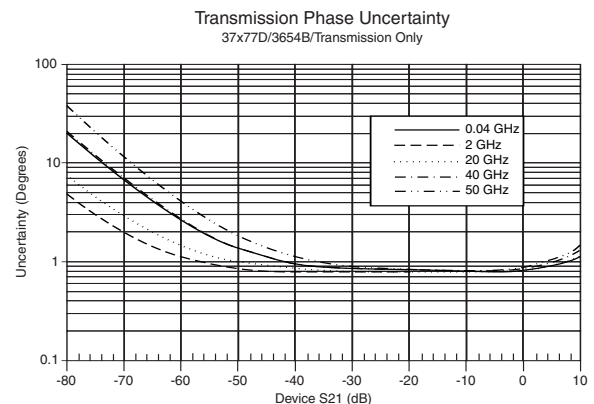
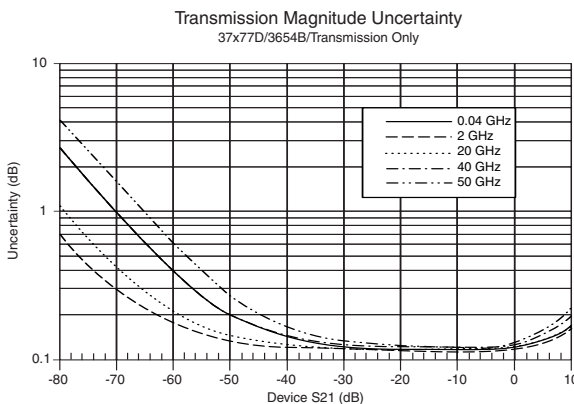

37X97D (40 MHz – 65GHz)

Model	Frequency ¹ (GHz)	Port 1 Power, Typical (dBm)		Noise Floor at Port 2 (dBm) ²		System Dynamic Range (dB)	
			With Option 15		With Option 15		With Option 15
37397D	0.04	10	10	-88	-88	98	98
	2	5	5	-110	-110	115	115
	20	2	1	-106	-105	108	106
	40	1	0	-98	-97	99	97
	50	-1	-3	-94	-93	93	90
	65	-2	-4	-82	-80	80	76
37297D	0.04	10	10	-88	-88	98	98
	2	5	5	-110	-110	115	115
	20	1	0	-107	-106	108	106
	40	1	0	-100	-99	101	99
	50	-1	-3	-96	-95	95	92
	65	-1	-3	-84	-82	83	79

Test Port Characteristics³

Connector	Frequency ¹	Directivity (dB)	Source Match (dB)	Load Match (dB)	Reflection Tracking (dB)	Transmission Tracking (dB)	Isolation (dB)
V (1.85 mm)	0.04	>40	>36	>40	±0.050	±0.050	>115
	2	>40	>36	>40	±0.050	±0.050	>115
	20	>40	>36	>40	±0.060	±0.070	>110
	40	>36	>32	>36	±0.060	±0.080	>100
	50	>34	>30	>34	±0.080	±0.100	>90
	65	>34	>28	>34	±0.100	±0.120	>80

NOTES: 1. Specifications between the stated frequencies are to be linearly interpolated as typical values.

2. RMS values – compensated for loss in available source power from test port cable connected between Port 1 and Port 2.

3. The specifications for Test Port Characteristics apply when the VNA Universal Test Port Adapters are connected, with or without phase equal insertables, to the test set ports and calibrated with the appropriate calibration kit at 23°C ±3°C using the SOLT calibration method with a sliding load to achieve 12-term error correction. (90 min. warm-up time is recommended.)

Measurement Uncertainty

The graphs give measurement uncertainty after 12-Term vector error correction. The errors are worst case contributions of residual directivity, load and source match, frequency response, isolation, network analyzer dynamic accuracy, and connector repeatability.

Reflection Measurements

Reflection Magnitude Uncertainty
37x97D/3654B/Reflection Only

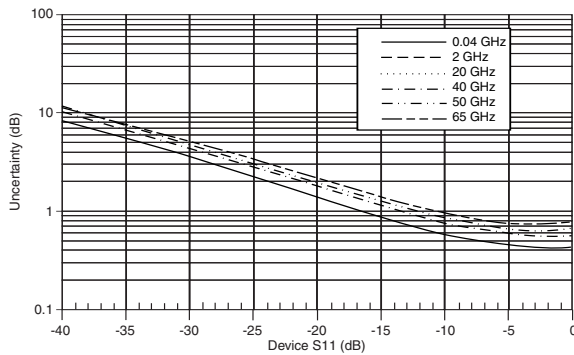

Reflection Phase Uncertainty
37x97D/3654B/Reflection Only

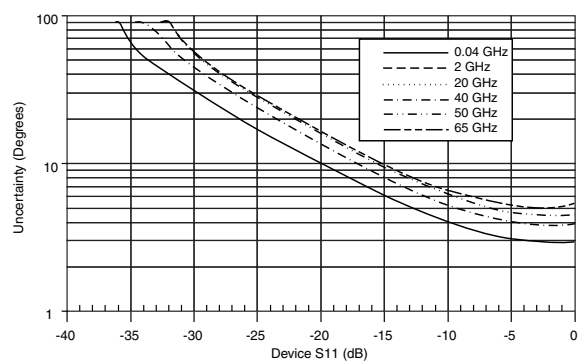

Transmission Measurements

Transmission Magnitude Uncertainty
37x97D/3654B/Transmission Only

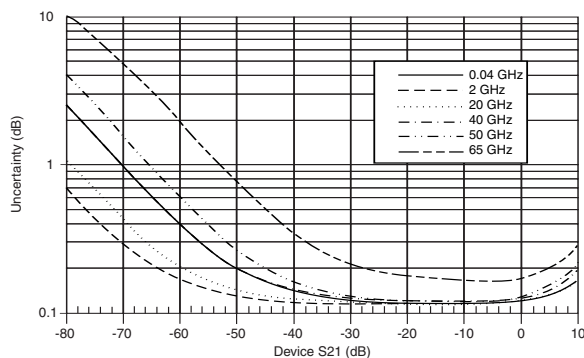

Transmission Phase Uncertainty
37x97D/3654B/Transmission Only

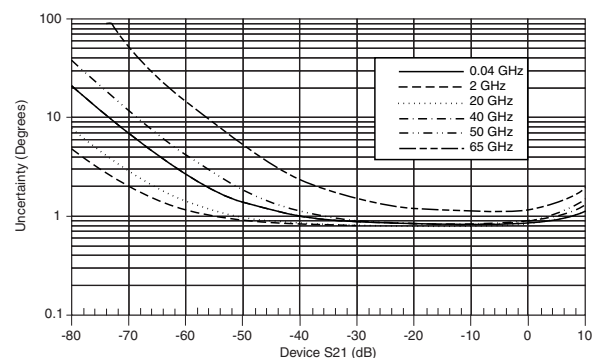

Signal Source Specifications

Resolution: 1 Hz

Frequency Stability:

Temperature: < 5x10⁻⁹ over 0° to 55°C range

Aging: <1 x 10⁻⁹/day

Source Power Level: The source power (dBm) may be set from the front panel menu or via GPIB. In addition, on 37300D models, the port 1 power may be attenuated in 10 dB steps, using the internal 70 dB (60 dB for 37377D and 37397D) step attenuator. Similarly, high input signals into port 2, not exceeding 1 watt, can be attenuated up to 40 dB, using the internal port 2 step attenuator.

Sweep Type: Linear, CW, Marker, or N-Discrete point sweep

Phase Noise:

>60 dBc/Hz at 10 kHz offset and 20 GHz center frequency

Spurious Response (Harmonics)

Frequency	Typical (at default power)
40 MHz – 20 GHz	<-40 dBc
20 GHz – 40 GHz	<-20 dBc
40 GHz – 65 GHz	<-20 dBc

Spurious Response (Non-harmonics):

<-35 dBc at maximum rated power

High Level Noise (pk – pk typical at 1 kHz I.F. BW)

Frequency	Magnitude (dB)	Phase (degrees)
40 MHz – 20 GHz	<0.04	<0.5
20 GHz – 40 GHz	<0.08	<1.0
40 GHz – 65 GHz	<0.25	<2.5

Receiver Noise Floor and System Dynamic Range into Direct Access Ports (Option 15 only)

*RMS values measured at 10 Hz IF BW with NO averaging applied)

Model	Frequency (GHz)	Typical Noise Floor* (dBm)	Power into b1 or b2 Ports at 0.2 dB Compression (dBm)	Typical System Dynamic Range (dB)
372XXD	0.04	-130	-12	>118
	2	-123	-10	>113
	20	-121	-7	>114
	40	-111	-8	>103
	50	-102	-3	>99
	65	-92	-3	>89
373XXD	0.04	-130	-12	>118
	2	-123	-9	>114
	20	-120	-6	>114
	40	-110	-6	>104
	50	-100	0	>100
	65	-90	0	>90

Power Flatness

Frequency	Flatness (dB)
40 MHz – 13.5 GHz	±1.5
13.5 GHz – 20 GHz	±2.0
20 GHz – 40 GHz	±3.0
40 GHz – 65 GHz	±5.0

Power Range

Model	Rated Power (dBm)	Minimum Power (dBm)	Resolution (dB)
37247D	5	-20	0.05
37269D	-7	-27	0.05
37277D	-7	-27	0.05
37297D	-7	-19	0.05
37347D	5	-90	0.05
37369D	-7	-97	0.05
37377D	-7	-87	0.05
37397D	-7	-79	0.05

37200D Block Diagram

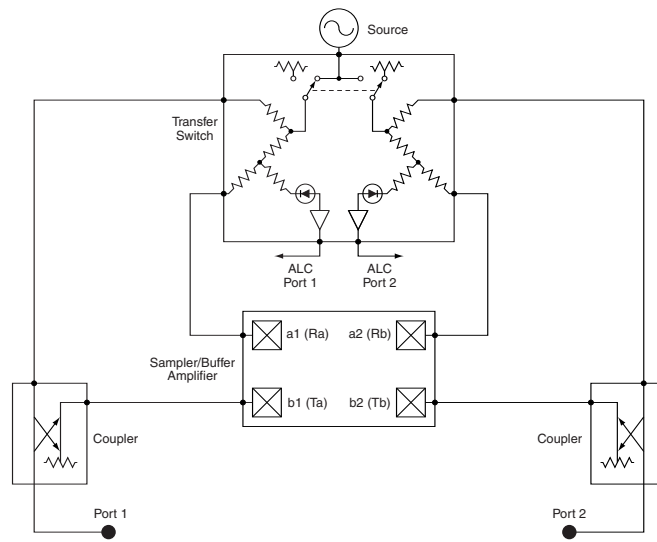

37200D Block Diagram with Option 15

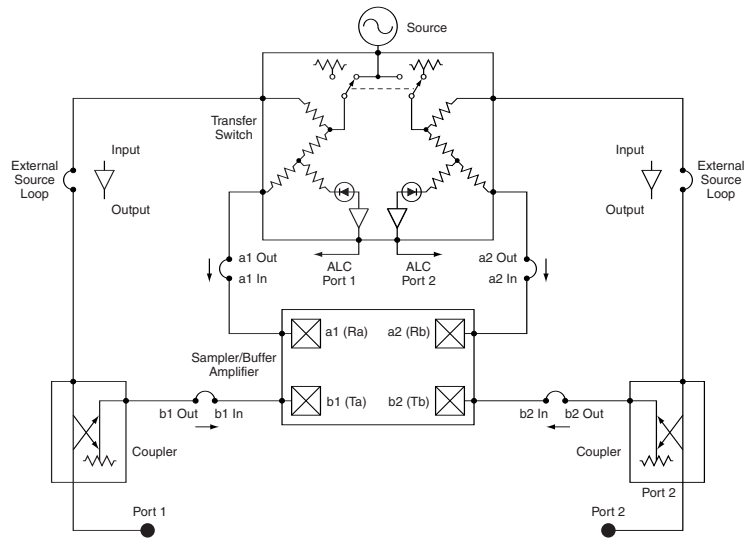

37300D Block Diagram

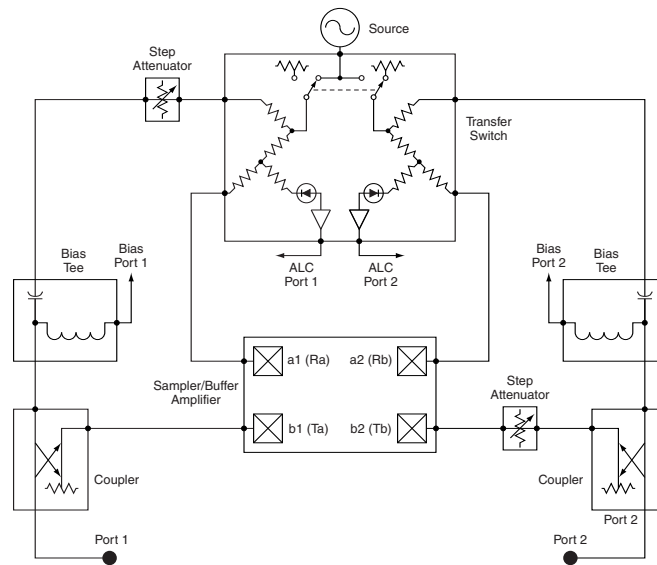

37300D Block Diagram with Option 15

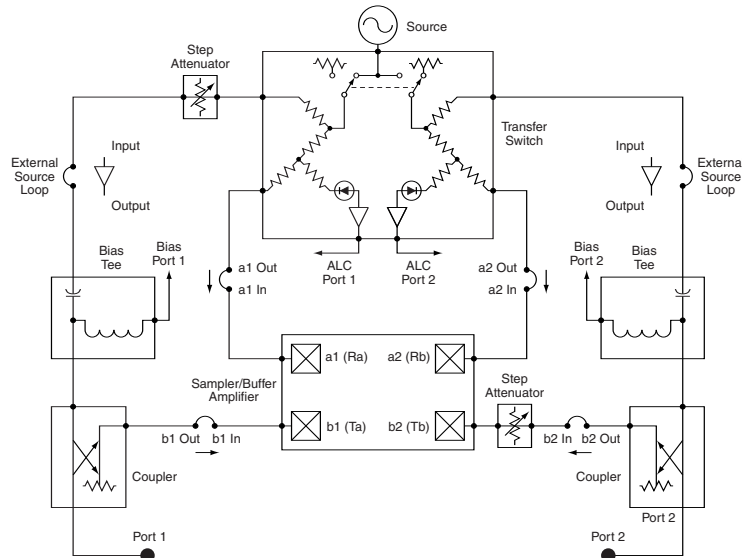

General

Power Requirements: 85-240 volts, 48-63 Hz, 540 VA maximum

Dimensions: 267 H x 432 W x 585 D mm
(10.5 H x 17 W x 23 D in.)

Weight: 27 kg (60 lb)-(2-man lift required)

Environmental: Conforms to MIL-PRF-28800F (Class 3)

Storage Temperature Range: -40°C to +75°C

Operating Temperature Range: 0°C to +50°C

Relative Humidity: 5% to 95% at +40°C

EMI: Meets the emissions and immunity requirements of
EN55011/1991 Class A/CISPR-11 Class A
EN50082-1/1993

IEC 801-2/1984 (4 kV CD, 8 kV AD)

IEC 1000-4-3/1995 (3 V/m, 80-1000 MHz)

IEC 801-4/1988 (500V SL, 1000V PL)

IEC 1000-4-5/1995 (2 kV L-E, 1 kV L-L)

Ordering Information

Models

37200D Economy Vector Network Analyzers

(see page 11 for block diagram)

The 37200D series is a high performance VNA designed to measure S-parameters for mainly passive devices.

- 37247D, 40 MHz to 20 GHz
- 37269D, 40 MHz to 40 GHz
- 37277D, 40 MHz to 50 GHz
- 37297D, 40 MHz to 65 GHz

37300D Premium Vector Network Analyzers

(see page 12 for block diagram)

The 37300D series is a VNA optimized to measure S-parameters for both active and passive devices. It offers the full suite of Lightning features, including gain compression, power sweep capability, internal bias tees and step attenuators, which are not available on the 37200D models.

- 37347D, 40 MHz to 20 GHz
- 37369D, 40 MHz to 40 GHz
- 37377D, 40 MHz to 50 GHz
- 37397D, 40 MHz to 65 GHz

System Options

- Option 1, Rack Mount Kit with Slides**
Rack mount kit containing a set of track slides (90° tilt capability), mounting ears, and front panel handles to let the instrument be mounted in a standard 19-inch equipment rack.
- Option 1A, Rack Mount Kit with Handles Only (No Slides)**
Rack mount kit containing a set of mounting ears and hardware to permanently mount the instrument in a standard 19-inch equipment rack.
- Option 2A, Time Domain Measurement Capability**
Analyze impedance discontinuities as a function of time or distance with Lightning's high speed time domain capability.
- Option 4A, External SCSI-2 Hard Disk Drive Compatibility**
Provides SCSI-2 rear panel connector for connection of an external SCSI Hard Disk. Removes internal Hard Disk Drive.
- Option 7A, Replaces K test port connectors with GPC-7 connectors**
- Option 7N, Replaces K test port connectors with N(m) connectors**
- Option 7NF, Replaces K test port connectors with N(f) connectors**
- Option 7S, Replaces K test port connectors with 3.5mm-(m) connectors**
- Option 7K, Replaces V test port connectors with Universal K(m) connectors**
- Option 15, Flexible test set**
Provides direct access to all four reference and test channels and adds two auxiliary source loops for each port for connecting amplifiers etc.
- Option 98, Z540/Guide 25 Calibration**
- Option 99, Premium Calibration**

Calibration Kits

Using Anritsu's precision calibration kits ensures accurate operation of your 37000D series VNA. These kits include precision components required to perform full 12 term calibrations. The AutoCal® modules are automatic precision calibrators that provide fast, repeatable, and accurate coaxial calibrations up to 40 GHz. The AutoCal system includes the module, serial cable, power supply, power cord, software disk, and operation manual.

Coaxial

Mechanical

- 3650 SMA/3.5 mm Calibration Kit
- 3650-1 SMA/3.5 mm Calibration Kit with Sliding Terminations
- 3651 GPC-7 Calibration Kit
- 3651-1 GPC-7 Calibration Kit with Sliding Terminations
- 3652 K Connector Calibration Kit
- 3652-1 K Connector Calibration Kit with Sliding Terminations
- 3653 Type N Calibration Kit
- 3654B V Connector Calibration Kit with Sliding Terminations
- 3656 W1 Connector Calibration/Verification Kit

AutoCal®

- 36581NNF N(m) to N(f), 40 MHz to 18 GHz
- 36581KKF K(m) to K(f), 40 MHz to 20 GHz
- 36582KKF K(m) to K(f), 40 MHz to 40 GHz
- 760-208 Transit Case for AutoCal

Waveguide

- 3655V WR-15 Waveguide Calibration Kit
- 3655V-1 WR-15 Waveguide Calibration Kit with sliding terminations
- 3655E WR-12 Waveguide Calibration Kit
- 3655E-1 WR-12 Waveguide Calibration Kit with sliding terminations
- 3655W WR-10 Waveguide Calibration Kit
- 3655W-1 WR-10 Waveguide Calibration Kit with sliding terminations

Verification Kits

Anritsu offers a complete line of coaxial verification kits to confirm your system's performance. All verification kits contain precision components with characteristics traceable to the US National Institute of Standards and Technology (NIST).

- 3663 Type N Verification Kit
- 3666 SMA/3.5 mm Verification Kit
- 3667 GPC-7 Verification Kit
- 3668 K Connector Verification Kit
- 3669B V Connector Verification Kit

Test Port Cable Converters

Test port cable converters are high precision, phase equal adapters, which can be used with K Connector AutoCal to adapt to either SMA or 3.5 mm connectors. Each set consists of four adapters, two of each sex that can be substituted for each other without affecting calibration accuracy.

- 36583S Test Port Cable Converter Set, SMA type
- 36583L Test Port Cable Converter Set, 3.5 mm type
- 36583K Test Port Cable Converter Set, K type

Test Port Cables

Flexible, High Performance, Phase Stable

- 3671A50-1** K(f) - GPC-7 Cables, 63.5 cm (25 in.), one pair
- 3671A50-2** K(f) - GPC-7 Cable, 96.5 cm (38 in.)
- 3671S50-1** K(f) - 3.5 mm(m) Cables, 63.5 cm (25 in.), one pair
- 3671S50-2** K(f) - 3.5 mm(m) Cable, 96.5 cm (38 in.)
- 3671K50-1** K(f) - K(m) Cables, 63.5 cm (25 in.), one pair
- 3671K50-2** K(f) - K(m) Cable, 96.5 cm (38 in.)
- 3671K50-3** K(f) - K(f) Cable and K(f) - K(m) Cable, 63.5 cm (25 in.)
- 3671V50B-1** V(f) - V(m) Cable, 63.5 cm (25 in.), one pair
- 3671V50B-2** V(f) - V(m) Cable, 96.5 cm (38 in.)

Semi-Rigid, Economy

- 3670A50-1** GPC-7 Cable, 30.5 cm (12 in.)
- 3670A50-2** GPC-7 Cable, 61 cm (24 in.)
- 3670N50-1** N(f) - N(m) Cable, 30.5 cm (12 in.)
- 3670N50-2** N(f) - N(m) Cable, 61 cm (24 in.)
- 3670NN50-1** N(m) - N(m) Cable, 30.5 cm (12 in.)
- 3670NN50-2** N(m) - N(m) Cable, 61 cm (24 in.)
- 3670K50-1** K(f) - K(m) Cable, 30.5 cm (12 in.)
- 3670K50-2** K(f) - K(m) Cable, 61 cm (24 in.)
- 3670KF50-1** K(f) - K(f) Cable, 30.5 cm (12 in.)
- 3670KF50-2** K(f) - K(f) Cable, 61 cm (24 in.)
- 3670V50-1** V(f) - V(m) Cable, 30.5 cm (12 in.)
- 3670V50-2** V(f) - V(m) Cable, 61 cm (24 in.)

Precision Adapters

Coaxial

- K220B** Adapter, DC to 40 GHz, 50Ω, K(m) to K(m)
- K222B** Adapter, DC to 40 GHz, 50Ω, K(f) to K(f)
- K224B** Adapter, DC to 40 GHz, 50Ω, K(m) to K(f)
- 34VK50** Adapter, DC to 46 GHz, 50Ω, V(m) to K(m)
- 34VKF50** Adapter, DC to 46 GHz, 50Ω, V(m) to K(f)
- 34VFK50** Adapter, DC to 46 GHz, 50Ω, V(f) to K(m)
- 34VFKF50** Adapter, DC to 46 GHz, 50Ω, V(f) to K(f)
- 34VV50** Adapter, DC to 65 GHz, 50Ω, V(m) to V(m)
- 34VVF50** Adapter, DC to 65 GHz, 50Ω, V(m) to V(f)
- 34VVF50** Adapter, DC to 65 GHz, 50Ω, V(f) to V(f)

Waveguide to Coax

- 35WR15V** Waveguide to Coax Adapter, 50 to 65 GHz (Usable to 67 GHz), WR15-V(m)
- 35WR15VF** Waveguide to Coax Adapter, 50 to 65 GHz (Usable to 67 GHz), WR15-V(f)
- 35WR19K**, Waveguide to Coax Adapter, 40 to 50 GHz (Usable to 54 GHz), WR19-K(m)
- 35WR19KF** Waveguide to Coax Adapter, 40 to 50 GHz, (Usable to 54 GHz), WR19-K(f)
- 35WR19V** Waveguide to Coax Adapter, 40 to 60 GHz, WR19-V(m)
- 35WR19VF** Waveguide to Coax Adapter, 40 to 60 GHz, WR19-V(f)
- 35WR22K** Waveguide to Coax Adapter, 33 to 50 GHz, WR22-K(m)
- 35WR22KF** Waveguide to Coax Adapter, 33 to 50 GHz, WR22-K(f)
- 35WR22V** Waveguide to Coax Adapter, 33 to 50 GHz, WR22-V(m)
- 35WR22VF** Waveguide to Coax Adapter, 33 to 50 GHz, WR22-V(f)
- 35WR28K** Waveguide to Coax Adapter, 26.5 to 40 GHz, WR28-K(m)
- 35WR28KF** Waveguide to Coax Adapter, 26.5 to 40 GHz, WR28-K(f)
- 35WR42K** Waveguide to Coax Adapter, 18 to 26.5 GHz, WR42-K(m)
- 35WR42KF** Waveguide to Coax Adapter, 18 to 26.5 GHz, WR42-K(f)
- 35WRD180K** Waveguide to Coax Adapter, 18 to 40 GHz, WRD180 (Double Ridge Waveguide) to K(m)
- 35WRD180KF** Waveguide to Coax Adapter, 18 to 40 GHz, WRD180 (Double Ridge Waveguide) to K(f)

Measurement Accessories

- MN4765A** O/E Calibration Module (40 MHz-65 GHz)
Unamplified photodiode module. Characterized to 65 GHz in both magnitude and phase using a NIST traceable standard. Used for electro-optical and opto-electrical measurements with the VNA.

GPIB Cables

- 2100-5** GPIB Cable, 0.5 m (1.6 ft.)
- 2100-1** GPIB Cable, 1 m (3.3 ft.)
- 2100-2** GPIB Cable, 2 m (6.6 ft.)
- 2100-4** GPIB Cable, 4 m (13.2 ft.)

Test Port Converters

Test port converters allow you to change the connector type on the VNA test ports.

20 and 40 GHz Test Sets

- 34UA50** Universal Test Port Connector to GPC-7 Converter
- 34UK50** Universal Test Port Connector to K(m) Converter
- 34UN50** Universal Test Port Connector to N(m) Converter
- 34UNF50** Universal Test Port Connector to N(f) Converter
- 34US50** Universal Test Port Connector to 3.5 mm(m) Converter

50 and 65 GHz Test Sets

- 34YA50** Universal Test Port Connector to GPC-7 Converter
- 34YK50B** Universal Test Port Connector to K(m) Converter
- 34YSS50** Universal Test Port Connector to SSMA(m) Converter
- 34YV50B** Universal Test Port Connector to V(m) Converter

Universal Test Fixtures (UTF)

Anritsu's UTF accommodates measurements in microstrip and coplanar waveguide. An optional MMIC attachment and substrate launchers help you test integrated circuits.

- 3680-20** 20 GHz Universal Test Fixture
- 3680K** 40 GHz Universal Test Fixture
- 3680V** 60 GHz Universal Test Fixture

UTF Accessories

- 36801K** 40 GHz Right-Angle Launcher
- 36801V** 60 GHz Right-Angle Launcher
- 36802** MMIC Attachment
- 36803** Bias Probe
- 36805-10M** Four 10 mil Substrate Launchers for the 36802 MMIC Attachment
- 36805-15M** Four 15 mil Substrate Launchers for the 36802 MMIC Attachment
- 36805-25M** Four 25 mil Substrate Launchers for the 36802 MMIC Attachment

UTF Calibration/Verification Kits

- 36804B-10M** 10 mil Microstrip Calibration/Verification Kit, DC to 60 GHz
- 36804B-15M** 15 mil Microstrip Calibration/Verification Kit, DC to 40 GHz
- 36804B-25M** 25 mil Microstrip Calibration/Verification Kit, DC to 20 GHz
- 36804B-25C** 25 mil Coplanar Waveguide (CPW) Calibration/Verification Kit (Includes CPW Jaws for UTF), DC to 20 GHz

Fixed Attenuators

Precision

- 41KB-3** Fixed Attenuator, 3 dB, DC to 26.5 GHz, 50Ω, K(m) to K(f)
- 41KB-6** Fixed Attenuator, 6 dB, DC to 26.5 GHz, 50Ω, K(m) to K(f)
- 41KB-10** Fixed Attenuator, 10 dB, DC to 26.5 GHz, 50Ω, K(m) to K(f)
- 41KB-20** Fixed Attenuator, 20 dB, DC to 26.5 GHz, 50Ω, K(m) to K(f)
- 41KC-3** Fixed Attenuator, 3 dB, DC to 40 GHz, 50Ω, K(m) to K(f)
- 41KC-6** Fixed Attenuator, 6 dB, DC to 40 GHz, 50Ω, K(m) to K(f)
- 41KC-10** Fixed Attenuator, 10 dB, DC to 40 GHz, 50Ω, K(m) to K(f)
- 41KC-20** Fixed Attenuator, 20 dB, DC to 40 GHz, 50Ω, K(m) to K(f)
- 41V-3** Fixed Attenuator, 3 dB, DC to 60 GHz, 50Ω, V(m) to V(f)
- 41V-6** Fixed Attenuator, 6 dB, DC to 60 GHz, 50Ω, V(m) to V(f)
- 41V-10** Fixed Attenuator, 10 dB, DC to 60 GHz, 50Ω, V(m) to V(f)
- 41V-20** Fixed Attenuator, 20 dB, DC to 60 GHz, 50Ω, V(m) to V(f)

Economy

- 43KB-3** Fixed Attenuator, 3 dB, DC to 26.5 GHz, 50Ω, K(m) to K(f)
- 43KB-6** Fixed Attenuator, 6 dB, DC to 26.5 GHz, 50Ω, K(m) to K(f)
- 43KB-10** Fixed Attenuator, 10 dB, DC to 26.5 GHz, 50Ω, K(m) to K(f)
- 43KB-20** Fixed Attenuator, 20 dB, DC to 26.5 GHz, 50Ω, K(m) to K(f)
- 43KC-3** Fixed Attenuator, 3 dB, DC to 40 GHz, 50Ω, K(m) to K(f)
- 43KC-6** Fixed Attenuator, 6 dB, DC to 40 GHz, 50Ω, K(m) to K(f)
- 43KC-10** Fixed Attenuator, 10 dB, DC to 40 GHz, 50Ω, K(m) to K(f)
- 43KC-20** Fixed Attenuator, 20 dB, DC to 40 GHz, 50Ω, K(m) to K(f)

Other Accessories and Tools

- 760-231** Lightning Transit Case
- 01-201** 5/16" Torque Wrench, 8 ft-lbs, for SMA, 3.5 mm, and K Connectors
- 01-202** Universal Test Port Connector Wrench
- 01-204** Anritsu Stainless Steel Connector Wrench

Printer

- 2000-1214** Desk Jet Printer (Includes Printer Cable, 2000-1216 Black Print Cartridge, 2000-1215 Color Print Cartridge, and US Power Cord)
- 2000-1228** Printer Extension Cable, 6 ft.
- 2000-1216** Black Print Cartridge
- 2000-1215** Color Print Cartridge
- 2000-1217** Rechargeable Battery for Desk Jet Printer
- 2000-663** Power Cord for Desk Jet Printer (Europe)
- 2000-664** Power Cord for Desk Jet Printer (Australia)
- 2000-1218** Power Cord for Desk Jet Printer (UK)
- 2000-666** Power Cord for Desk Jet Printer (Japan)
- 2000-667** Power Cord for Desk Jet Printer (South Africa)

Extended Service Options

On-Site Support Plans

- Option ES31** 3 Year On-Site Repair
- Option ES37** 3 Year On-Site Standard Calibration
- Option ES38** 3 Year On-Site Premium Calibration

Return-to-Service Center Support Plans

- Option ES32** 3 Year Return-to-Service Center Standard Calibration
- Option ES34** 3 Year Return-to-Service Center Premium Calibration
- Option ES50** 5 Year Return-to-Service Center Repair Only
- Option ES52** 5 Year Return-to-Service Center Standard Calibration
- Option ES54** 5 Year Return-to-Service Center Premium Calibration
- Option ES55** 5 Year Return-to-Service Center Repair plus Standard Calibration
- Option ES56** 5 Year Return-to-Service Center Repair plus Premium Calibration

Upgrade Options

- 37200D to a Higher Frequency 37200D
- 37200C to an Equivalent 37200D
- 37300D to a Higher Frequency 37300D
- 37300C to an Equivalent 37300D



SALES CENTERS:

United States (800) ANRITSU
Canada (800) ANRITSU
South America 55 (21) 2527-6922

Europe 44 (0) 1582-433433
Japan 81 (46) 223-1111
Asia-Pacific (65) 6282-2400

Microwave Measurement Division
490 Jarvis Drive, Morgan Hill, CA 95037-2809
<http://www.us.anritsu.com>

Anritsu

Discover What's Possible®